



OZB MANUAL ACTUATORS

Unlock the power of seamless valve control with OZB Manual Actuators. Our actuators are meticulously designed to govern the precise opening and closing of valves, providing you with unparalleled control and reliability in your operations.



KEY FEATURES

Versatile Compatibility

OZB actuators seamlessly integrate with both butterfly and slide valves, offering a comprehensive solution for your diverse valve control needs. Whether you're working with butterfly valves or slide valves, OZB has you covered.

Manual, Pneumatic, and Electromotor Options

Choose the actuation method that suits your requirements. OZB Actuators are available in manual, pneumatic, and electromechanical types, ensuring flexibility and adaptability for your specific application.



ABN: 35 139 258 816

PO Box 111, Charlestown NSW 2290
Unit 7/8 Kilcoy Drive, Tomago NSW 2322
P: 1300 026 011 | E: graham@bulkquip.com.au
www.bulkquip.com.au

ACM MANUAL ACTUATORS: TAILORED FOR BUTTERFLY VALVES

ACM Series manual levers are engineered with precision for optimal performance with butterfly valves. The electro-galvanized coated carbon steel frame not only ensures durability but also provides an ergonomic grip for effortless control via the EPDM Covered Handle.

ACM13

Experience precision at its finest. The ACM13 is designed for use with butterfly valves ranging from 100-300mm in diameter. Achieve smooth and reliable valve control with this specialized manual actuator.

ACM13

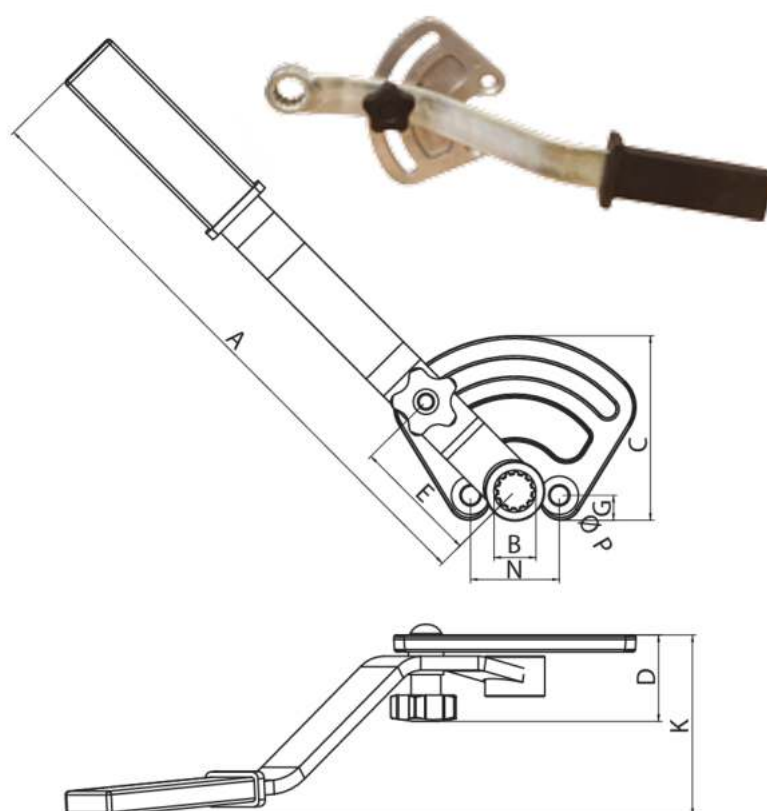

Type	A (mm)	B (mm)	C (mm)	D (mm)	E (mm)	G (mm)	N (mm)	P (mm)	K (mm)	Weight (kg)
ACM13	345	22x19	105	51	70	14	50	10,5	110	1.2

ACM34

The ACM34 is designed for use with butterfly valves ranging from 350-400mm in diameter.

ACM34

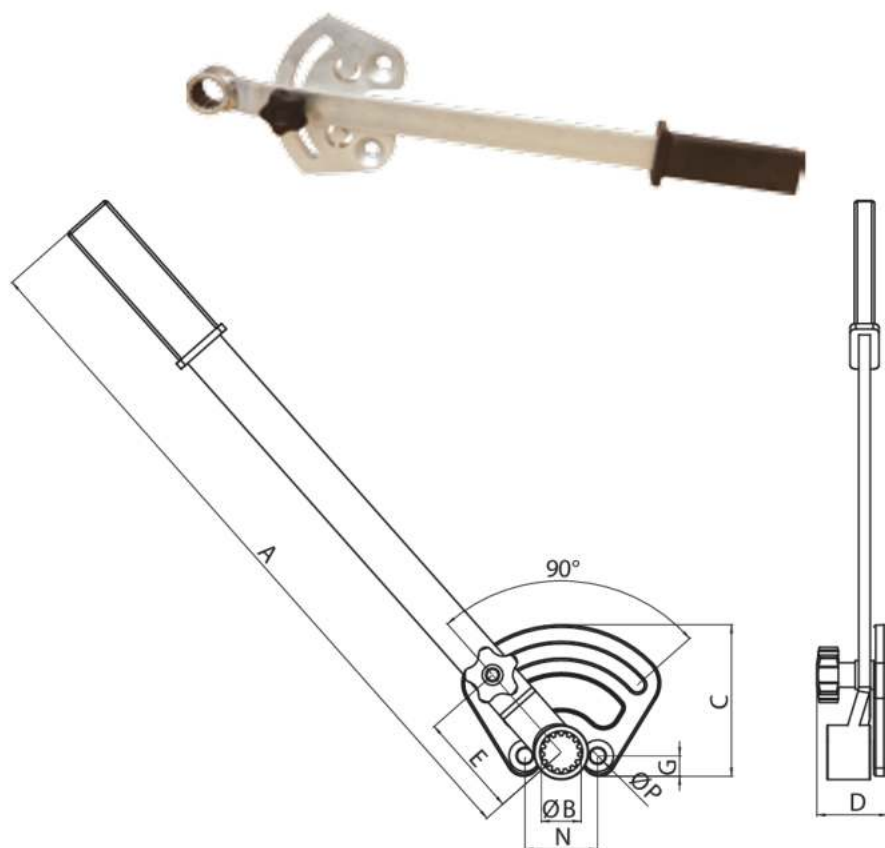

Type	A (mm)	B (mm)	C (mm)	D (mm)	E (mm)	G (mm)	N (mm)	P (mm)	Weight (kg)
ACM34	500	28x25	105	55	72	14	50	10.5	2.2

Embrace the power of precise valve control with OZB Manual Actuators. Contact us today to discover how our actuators can elevate the efficiency and reliability of your valve systems.

ACMS SERIES MANUAL LEVERS

The ACMS series manual levers are manufactured specifically for slide valves, providing a trouble-free and durable service life.

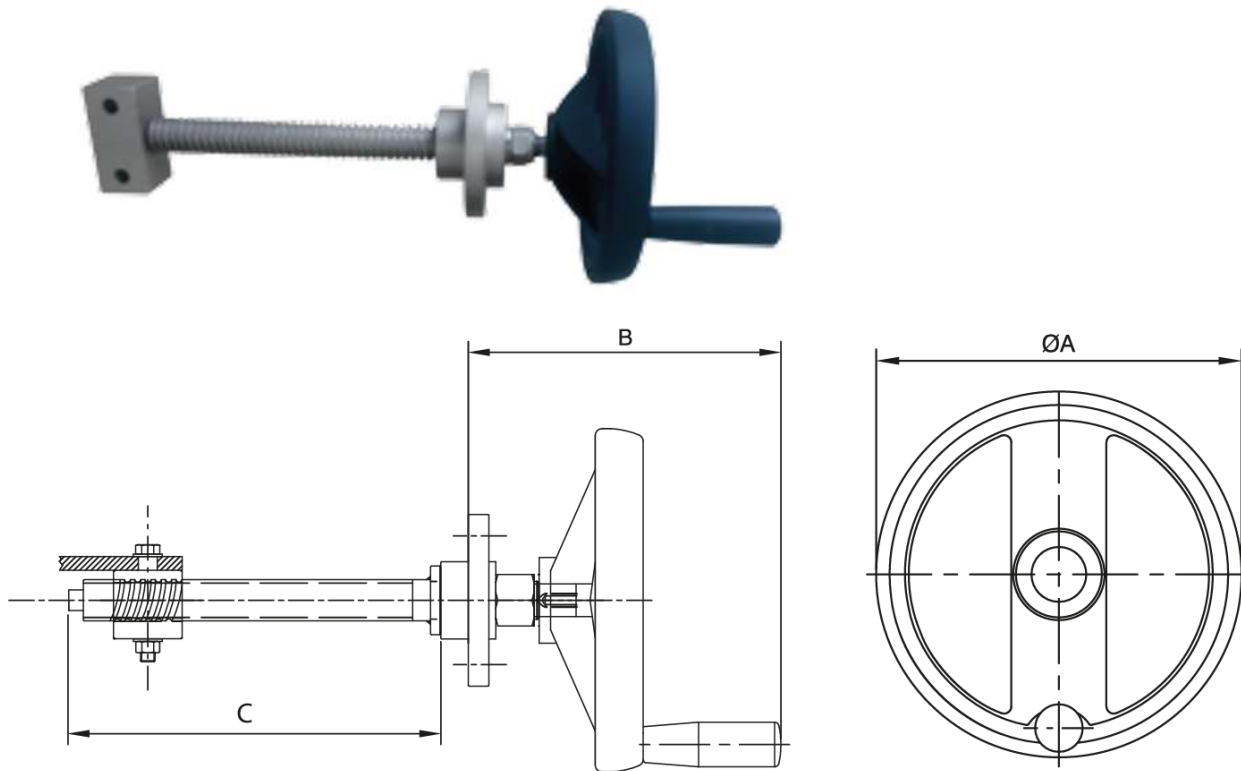

Type	ØA (mm)	B (mm)	C (mm)	Weight (kg)
ACMS150	200	180	190	2.0
ACMS200	200	180	230	2.4
ACMS250	200	180	285	2.8
ACMS300	200	180	335	3.0
ACMS350	250	220	425	5.2
ACMS400	250	220	470	5.8