

# Flap Diverter Valves VAB

PNEUMATIC CONVEYING

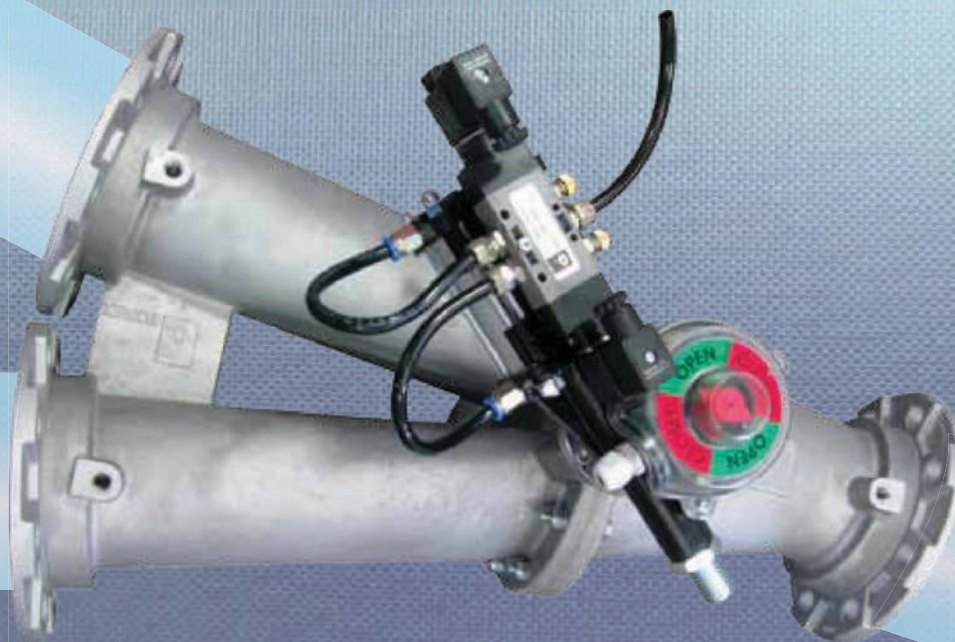

**COMPLETE**

**VERSATILE**

**COMPACT  
SIMPLE**

# Flap Diverter Valves VAB

## VERSATILE SOLUTION FOR PNEUMATIC CONVEYING SYSTEMS

The flap diverter valve uses a swinging flap to divert material from one duct to another. The VAB Flap Diverter Valves are fitted on pneumatic conveying ducts whenever it is required to switch the flow of material to different production lines.

### Features

#### VALVE

- Casing: cast aluminium alloy;
- Mobile flap seal: EPDM (white colour, food-grade certified, antistatic);  
Metal plate - 304 Stainless Steel
- Working temperature: from - 20°C to 80°C
- Working pressure: max.+ 2.0 bar and -0.3 bar.
- Various actuators available
- Diameter Range: 50 mm – 65 mm - 80 mm – 100 mm – 125 mm – 150 mm – 200 mm
- Cast aluminium alloy or nickel plated version both available with ATEX certification for Group II Cat. 1D/3D c T 135°C on request
- It can be used either as diverterting or converging

#### ACTUATOR

- Pneumatic Actuator** (CP063 for VAB 50 to VAB 125 - CP101 (VAB 150 – VAB 200 + MIC23 for all sizes)
  - Voltage supply: 24 V AC, 24 V DC, 110 V AC, 230 V AC;
- Electric Actuators** (AE4011 for VAB50 to VAB125 – AE5011 for VAB150-VAB200)
  - Voltage supply: 230/400 V AC 50/60 Hz
- Manual Actuator** (CM4 for all sizes)
  - Manually operated

### Overall Dimensions

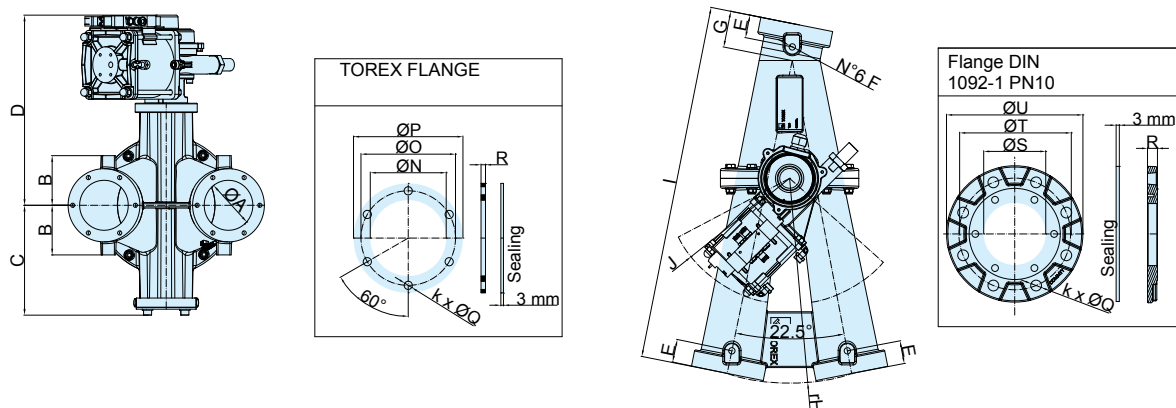

Size	A	B	C	E	F	G	rH	I	Pneumatic Actuator		Electric Actuator	
									D	rJ	D	rJ
50	50	60	153	32	70	45	448	493	281	205	363	275
65	65	70				47	497	545				
80	80	80				59	514	574				
100	100	90	178	37	M16	559	629	712	305.5	205	387.5	275
125	125	110				74	639	712				
150	156	125	277	65	M16	74	745	818	402	205	412.5	290
200	206	150				857	922	818				

Dimensions in mm

## Benefits

### 1 Quick integration into the process



#### TOREX® FLANGES

- Provided with:
- Carbon steel counter-flanges
  - 304 Stainless Steel counter-flanges
- TOREX® flanges can be welded to the pneumatic duct  
Dimensions are the same as for VAR Diverter Valves

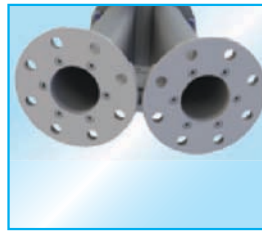

#### DIN FLANGE 1092-1 PN 10

- Cast aluminium alloy available
- The dimensions of these flanges are the same as for VM Pinch Valves

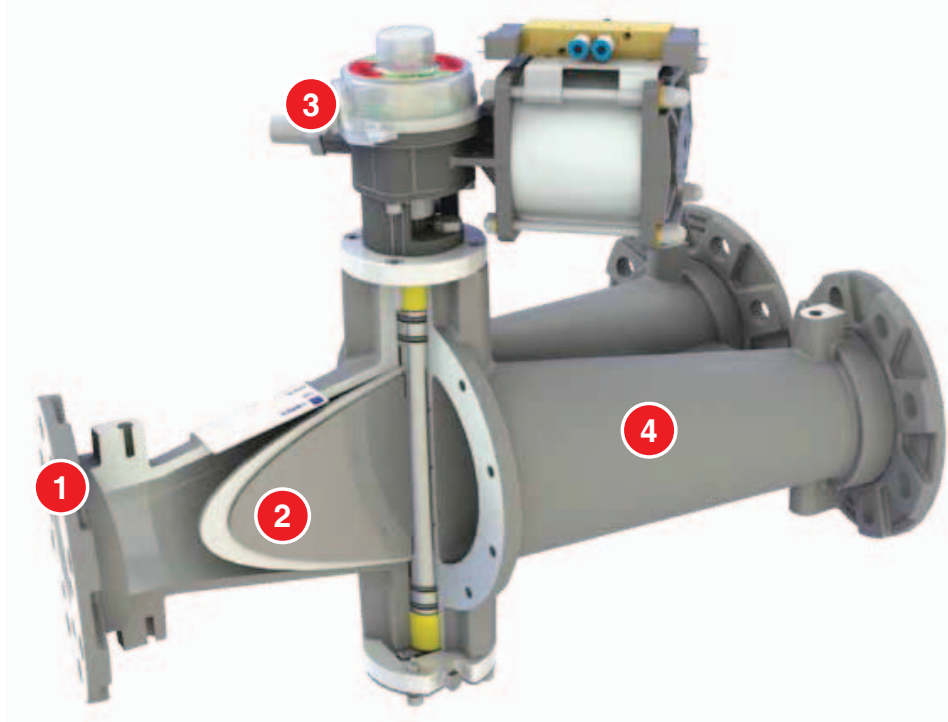

### 2 Switching Flap

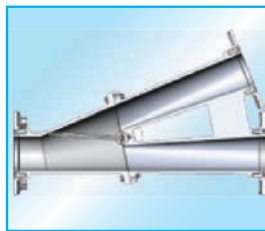
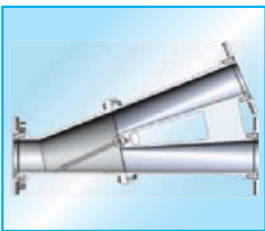

Easy to use as Diverter or Converter

- Narrow diverting angle of 22.5°
- Low pressure drop due to minimum transition effect
- Smooth internal surface (no lodgement points)
- Modular design and easy maintenance thanks to small numbers of components
- Lightweight and compact overall dimensions

### 3 Various type of actuators



Pneumatic Actuator CP063/CP101  
Working Pressure: 2-7 bar



Electric Actuator AE40A11  
Power: 0.18 kW  
Protection: IP 55,  
Voltage: 50 Hz - 230/400 Volt



Manual Actuator CM4

### 4 Nickel Plated Version



- No contamination thanks to food-grade certified Nickel plating
- Corrosion resistant
- Higher surface hardness



## Application

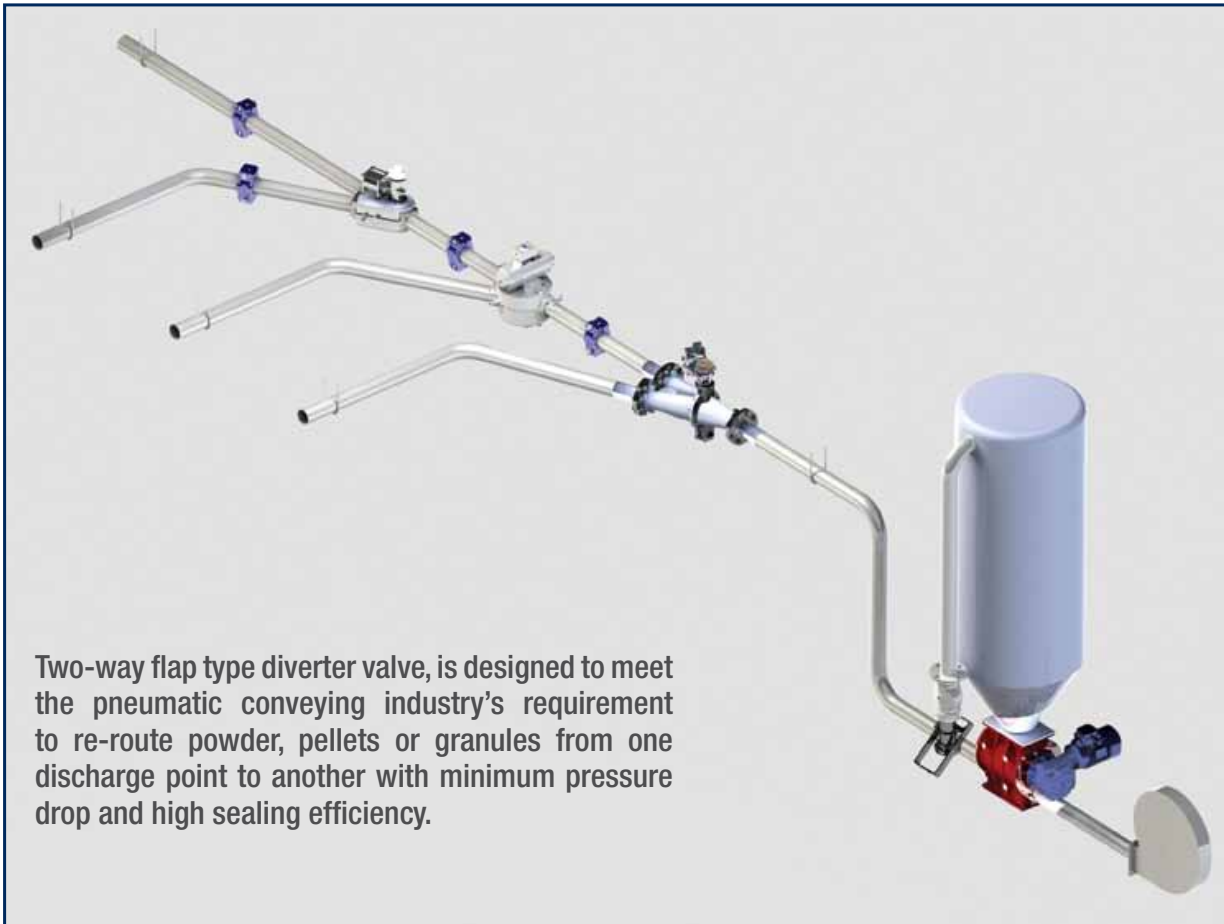

Two-way flap type diverter valve, is designed to meet the pneumatic conveying industry's requirement to re-route powder, pellets or granules from one discharge point to another with minimum pressure drop and high sealing efficiency.