



Bin Activators



Bin activators play a crucial role in facilitating the extraction of powders and granules from storage tanks.

Available in diameters ranging from 1000 to 1800mm, these activators are ideal for environments with non-explosive, non-toxic materials, and non-flammable gases. The option of stainless-steel construction enhances versatility. Operating optimally within an ambient temperature range of -20°C to 40°C , these bin activators ensure effective performance when the material temperature falls between -20°C and 60°C . The versatility of these bin activators makes them a reliable solution for various industries requiring efficient powder and granule extraction.

COMPONENTS

1. Silo flange
2. Deflector
3. Suspension
4. Sleeve
5. Vibrator
6. Outlet cone

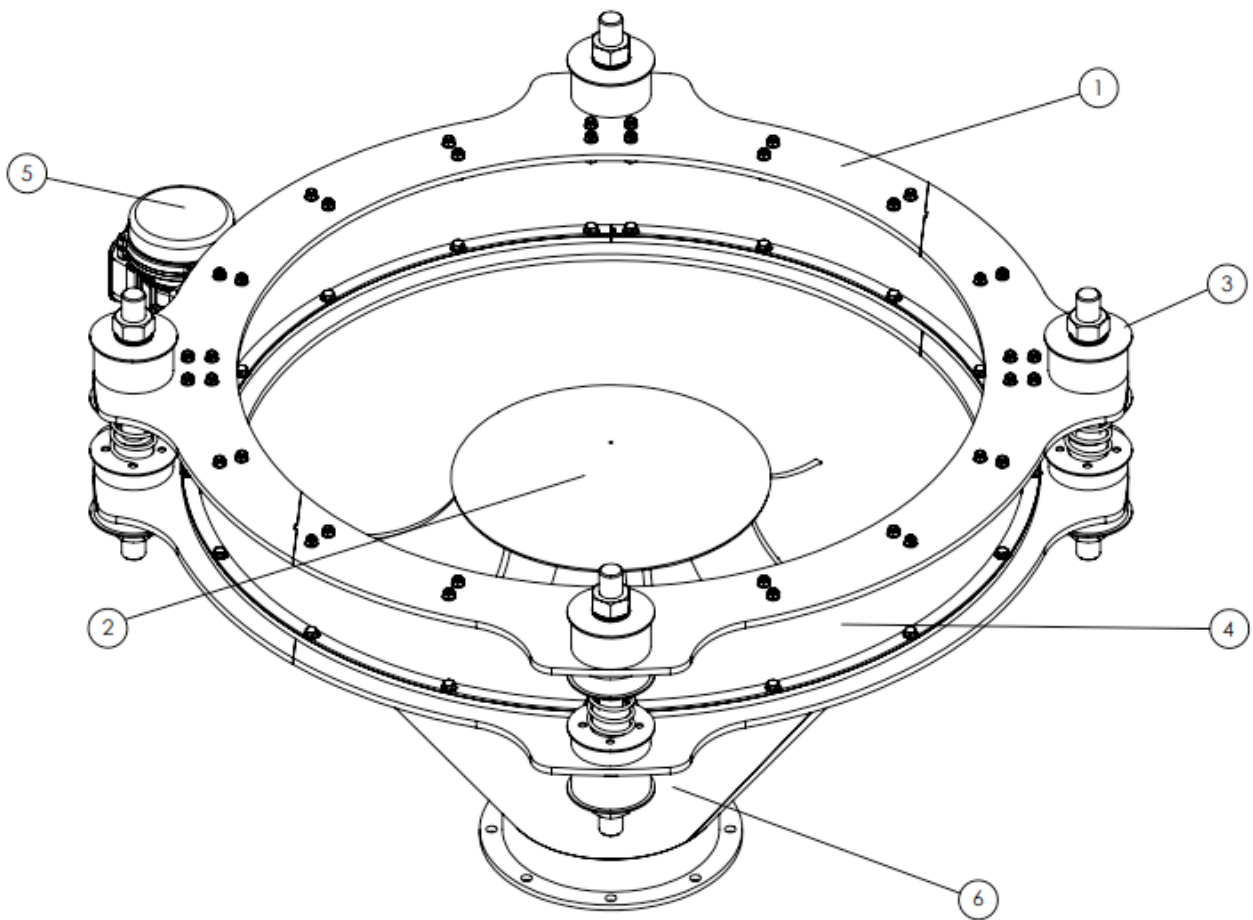

OVERALL DIMENSIONS

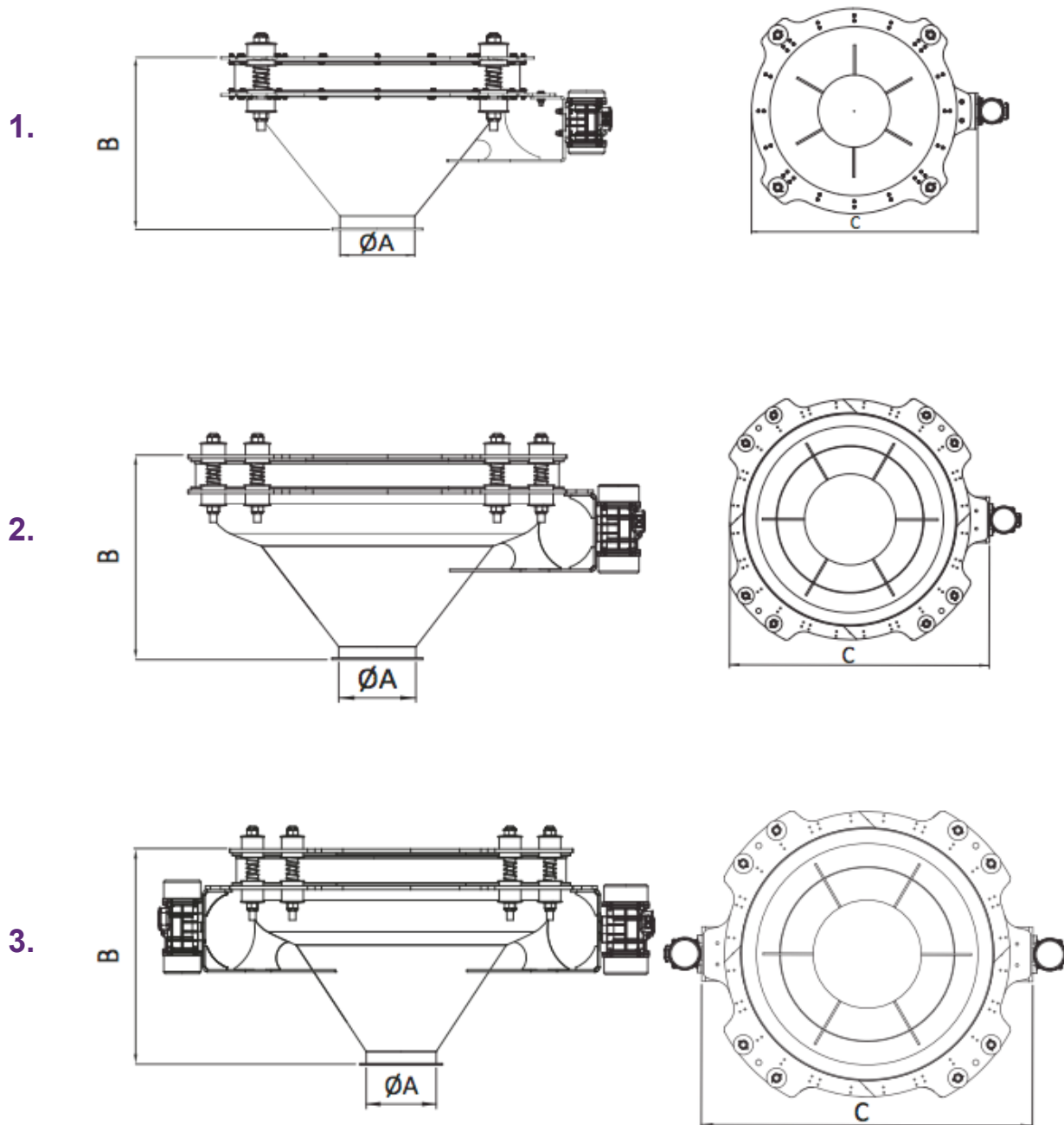

Type	Figure	ØA (mm)	B (mm)	C (mm)	Suspension (pcs)	Vibrator	
						Type	Pcs
Sec.1.10.04	1	273	700	1260	4	EMV 200/15	1
Sec.1.15.08	2	323	900	1710	8	EMV 750/15	1
Sec.1.15.12	2	323	900	1710	12	EMV 750/15	1
Sec.1.18.12	3	323	1000	2155	12	EMV 750/15	2